



# Probabilistic multi-scale modeling of interdependencies between critical infrastructure systems for resilience

Chloe Johansen  and Iris Tien

School of Civil and Environmental Engineering, Georgia Institute of Technology, Atlanta, GA, USA

## ABSTRACT

The prevalence of aging infrastructure and an increase in cascading failures have highlighted the need to focus on building strong, interdependent infrastructure systems to increase resilience. To understand the ways infrastructure systems depend on one another, we define three comprehensive interdependency types – service provision, geographic, and access for repair. We propose a methodology to model interdependencies probabilistically using a novel Bayesian network approach. By understanding how these interdependencies affect the fragility of overall systems, infrastructure owners can work towards creating more resilient infrastructure systems that sustain less damage from natural hazards and targeted attacks, and restore services to communities rapidly. Generalized expressions to create the multi-scale Bayesian network model accounting for each interdependency type are presented and applied to a real interdependent water, power, and gas network to demonstrate their use. These models enable us to probabilistically infer which interdependencies have the most critical effects and prioritize components for repair or reinforcement to increase resilience.

## ARTICLE HISTORY

Received 5 October 2016  
Accepted 12 May 2017

## KEYWORDS

Critical infrastructure resilience; interdependencies; Bayesian networks; probabilistic modeling; risk assessment

## Introduction

Cascading failures, such as the 2003 Northeast blackout, have revealed the need to address interdependencies between systems to assess and improve infrastructure resilience, i.e. ‘the ability to prepare for and adapt to changing conditions and withstand and recover rapidly from disruptions’ (White House, 2013). Cascading failures refer to the case where failure of one component induces failures in other components and systems. The cause of the Northeast blackout was a tree coming in contact with power lines, which caused overloads and outages throughout the power grid in the Northeastern United States and Ontario, Canada. The cascading effects were disruptions of the drinking water, transportation, and communication networks because of their dependence on the power network (Hernandez-Fajardo & Dueñas-Osorio, 2013). To mitigate this problem for future hazards, system reinforcement and recovery for resilience must be conducted with a focus on the connections and interdependencies that exist between infrastructure systems.

In addition, infrastructure in the United States is aging. Many infrastructure components are at or near the end of their useful lives including drinking water pipes and mains over 100 years old and power components that

originated in the 1880s. The operation of infrastructure is critically tied to the resilience of communities (White House, 2013). Providing a quantitative way to measure the impact of critical infrastructure on communities is essential for improving resilience (Johansen, Horney, & Tien, 2016). Some literature regarding the quantification of resilience for communities and infrastructure networks can be found in Bruneau and Reinhorn (2004), where measures of increased resilience are reduced failure probabilities and reduced consequences from failure; Franchin and Cavalieri (2015), in which resilience is based on displaced population, road damage, and recovery strategy; and Guidotti et al. (2016), where resilience is quantified based on the loss of functionality and delay in recovery. The investment required to repair or replace all vulnerable components, however, is too large to make such an effort feasible. The American Society of Civil Engineers estimated in its 2013 Infrastructure Report Card that \$3.6 trillion in infrastructure investment is needed by 2020 to improve these systems (American Society of Civil Engineers, 2013). Thus, prioritizing repair and replacement by identifying the most critical components in a system will support decision-making in the allocation of investment to create more resilient systems.

In this paper, we present a novel methodology to do this that accounts for the complex interdependencies between infrastructure systems. Interdependencies refer to relationships between two or more different infrastructure systems, such as between power and natural gas or water and power. We first define three general and comprehensive types of interdependencies – service provision, geographic, and access for repair – that significantly affect infrastructure resilience. We then establish a methodology to model each of these quantitatively using a novel Bayesian network (BN) approach. This enables a probabilistic and dynamic analysis of interdependent infrastructure systems to improve resilience. In the following sections of this paper, we: provide background on BNs and a comparison with other approaches; describe our three defined interdependency types; present generalized expressions for each interdependency to build the BN model; apply the methodology to a real interdependent water, power, and gas network; and present example inference calculations obtained using the method.

## Background

There are many approaches to modeling interdependencies between critical infrastructures. These include empirical, agent-based, system dynamics-based, economic theory-based, and network-based approaches (Ouyang, 2014). The method used in this paper is a network-based approach – one where nodes represent different infrastructure components and links represent the connections between them. Network-based approaches are able to analyze system components considering all capacities of resilience – resistance, absorption, and restoration. Adaptive capacities are also considered. Resistance is the ability for infrastructure systems to prevent and withstand potential hazards, prior to the hazard occurring. Absorption refers to lessening the effects of a hazard during the event, including taking actions to accelerate decision-making in the case of an emergency and utilizing system redundancies. Restoration refers to activities to support recovery, including community notifications and optimized sequences of response. Adaptive capacities include increasing the strength of infrastructures and installing monitoring for the states of systems to decrease vulnerability to future disasters (Johansen et al., 2016). Network-based approaches are effective at evaluating the ability of the network to prevent events that lead to large consequences, determining the effects of improving absorptive capacities of critical infrastructure components, and analyzing how well the network supports advanced design decisions to quickly find restoration priorities (Ouyang, 2014).

While network-based approaches enable identification, description, and analysis of most resilience strategies,

they can require a large quantity of data input to generate the network graph. Therefore, these methods have typically focused on only one or a few systems, e.g. only the water and power networks (Dueñas-Osorio, Craig, & Goodno, 2007), the reliability of transportation systems (Kang, Song, & Gardoni, 2008; Kurtz, Song, & Gardoni, 2015; and Lee, Song, Gardoni, & Lim, 2011), or cascading failures within just the power grid (Korkali, Veneman, Tivnan, & Hines, 2014). The approach in this paper aims to be generalizable to any infrastructure system and to any number of systems. In addition, the BN model's ability for updating – new information entered at any node in the BN propagates to all nodes in the network – addresses the limitations of other static approaches, such as the model proposed by Haines (2008) and input-output-based methods (Leontief, 1951 and Rose & Miernyk, 1989). Static approaches describe the state of a system at one point in time rather than allowing for updating as components age and change.

Specifically, the BN framework allows for incorporation of both prior and updating information. Prior knowledge about each component is added to the BN during construction of the network. When new information is learned about a component, including through measurements and observations, it is updated, with the effects propagated to all other nodes in the system through inference. Finally, previous studies have emphasized the importance for infrastructure managers to focus on the components that are most critical in the design of retrofit strategies (Dudenhoffer, Permann, & Manic, 2006; Ouyang, 2014; Rinaldi, Peerenboom, & Kelly, 2001; Zhang & Peeta, 2011).

BNs have been previously used for infrastructure modeling in Tien and Der Kiureghian (2015, 2016). In general, past studies used BNs to analyze small systems of 5–10 components (e.g. Bobbio, Portinale, Minichino, & Ciancamerla, 2001; Kim, 2011); the algorithms developed allow BNs to be used for much larger systems (Tien & Der Kiureghian, 2013). Another application of BNs for infrastructure reliability assessment is in Bensi, Kiureghian, and Straub (2013), where an efficient modeling algorithm was developed to create chain-like BN structures to model infrastructure systems. Mahadevan, Zhang, and Smith (2001) used BNs to assess the reliability of structural systems accounting for multiple failure sequences and correlations between component-level limit states. A case study performed by Hosseini and Barker (2016) used BNs to assess the infrastructure resilience of inland waterway ports. In all of these studies, BNs were used to model and assess the performance of single infrastructure systems. In contrast, this study presents a BN framework to model multiple infrastructures, and specifically the interdependencies between them.

## Proposed method

We propose a BN framework to model the interdependencies between infrastructure systems. The BN is a probabilistic directed acyclic graph comprised of nodes and links. A directed graph is made up of edges that are directional. Acyclic refers to the lack of cycles in the network, i.e. that no closed path exists in the network. Each node represents a random variable and is defined by a conditional probability table (CPT). For variables with parent nodes, the CPT consists of the conditional probabilities of the states of the child node given the states of the parents. For variables without parent nodes, the CPT consists of the marginal probabilities. We take a multi-scale approach, with the BN consisting of component nodes as parents of system nodes to represent infrastructure networks; i.e. system performance depends on the states of individual components. In our formulation, the component nodes are defined by the failure probabilities of each component; a system node represents the state of an overall system or subsystem. Components can be dependent on each other and children of other common parent nodes. BNs are useful because they are able to capture dependencies between components both within individual systems and across infrastructure networks.

In this paper, the term dependencies are used to define the relationships between specific nodes in the BN according to classical BN terminology. The term interdependencies are used to define the relationships between physical components of an infrastructure network. Some physical relationships may be unidirectional such that one component's functionality depends on another, and the reverse is not true. However, as each interdependency type we define may be bidirectional, the term interdependency is used in all cases when referring to the relationships between physical components.

In addition, in the BN formulation, super-components are used to simplify the network (Der Kiureghian & Song,

2008; Tien, 2014). Adding super-component nodes is a way to model multiple components more efficiently by representing several components as a single node. In this case, we define a super-component when its state is known in the event of failure of any one of its constituent components. Therefore, individual components that are in a series configuration in the infrastructure network are modeled as parents in the BN of a super-component node.

In our methodology, the BN framework is also combined with a minimum link set (MLS) formulation to create the network model. A MLS is a minimum set of functioning components required for the system to function. For a physical infrastructure system, a MLS is a set of the fewest components that must be in the functioning state for a resource, e.g. water, power, or gas, to be transported from a source node to any other node that requires that resource in the network. Failure of any component within a MLS leads to failure of the MLS. A depth-first search-based method is used to find the MLSs for a given system (Jiang, Bai, Atkin, & Kendall, 2016). With this formulation, we create a multi-scale model where the components in a MLS are parents of a MLS node in the BN, and the MLSs are parents of the system node. Combining MLSs with super-components reduces the number of parents in some MLSs, therefore, decreasing the size of CPTs in the network. An example system is shown in Figure 1 to illustrate the BN model and implementation of super-components and a MLS formulation.

Figure 1(a) shows a five-component system with series and parallel connections. The system survives if resources can be transported from the start to end nodes. There are three MLSs in this example. For the system to function, components  $C_1$  and  $C_2$  and one of components  $C_3$ ,  $C_4$ , or  $C_5$  must be in the operational state.

Figure 1(b) shows the BN representation of the system. The component nodes are defined by the failure probabilities of each component.  $C_1$  and  $C_2$  are parents of the

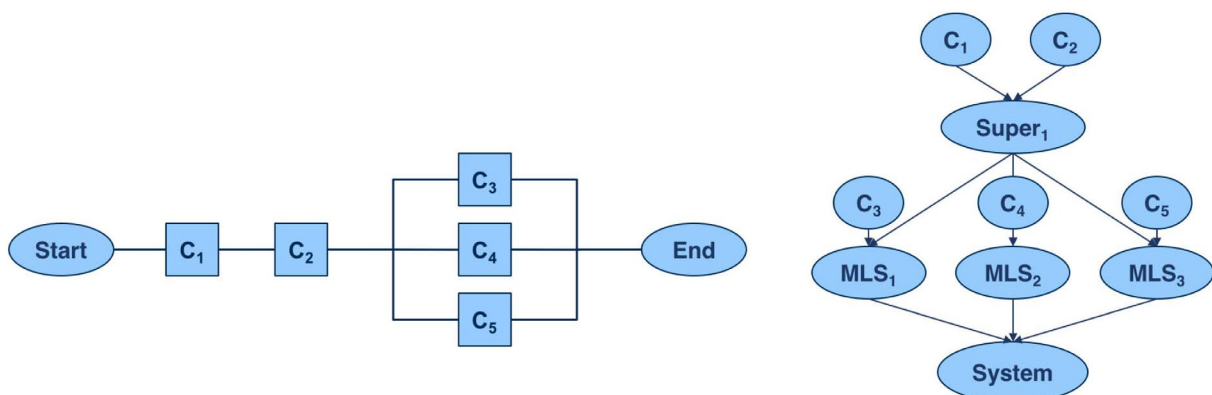

**Figure 1.** (a) Example system and (b) Bayesian network representation of example system with super-component and minimum link set nodes.

super-component node (Super<sub>1</sub>), which along with the other component nodes are parents of the MLS nodes. The MLS nodes are parents of the system node, which indicates performance of the system overall. In this example, each component is in one of two states – working or failed. The described approach can easily be extended to multi-state systems using max flow-min cut methods. For the two-state case, the CPT of a component node  $C_i$  is described by Equation (1), where  $p_f$  represents the probability of failure of the component. The probabilities of failure considered in this paper are calculated using fragility curves. These refer to physical failure of components due to direct damage.

$$P(C_i) = \begin{cases} 1 - p_f & \text{if } C_i \text{ working} \\ p_f & \text{if } C_i \text{ failed} \end{cases} \quad (1)$$

The CPTs for MLS nodes are binary as the MLS is functioning if all of its parent nodes are working, and the MLS is failed if any one of its parent nodes is failed. The CPT for a MLS node  $MLS_i$  is thus constructed as shown in Equation (2).  $C_{1i}$  to  $C_{ni}$  are the components that comprise the MLS. The CPTs for super-component nodes are similarly constructed.

$$P(MLS_i = \text{working}) = \begin{cases} 1 & \text{if } C_{1i}, \dots, C_{ni} \text{ working} \\ 0 & \text{otherwise} \end{cases} \quad (2)$$

### Model of Interdependencies

Interdependencies between infrastructure systems exist when the states of two or more components from different systems depend on one another. This dependence can take several forms. Previously, four classes of interdependencies were proposed (Rinaldi et al., 2001). These are physical – the state of one node is dependent on the material output of another, cyber – a component's state is dependent on information transmitted from another infrastructure system, geographic – a local environmental variable affects the states of multiple components, and logical – any other presumed interdependency. However, to specifically address infrastructure resilience, the authors define three explicit types of interdependencies that comprehensively address the interdependent relationships between infrastructure systems. These are service provision, geographic, and access for repair interdependencies.

Our definition of service provision interdependency includes both the physical and cyber interdependencies defined previously, simplifying those classifications into a single category. Whether the output a component depends on is physical in nature, such as water, or cyber, such as information, it is the output from another system that is needed for functioning. The geographic interdependency previously defined is consistent with our definition. The

logical interdependency is unclear and would be covered by one of the interdependency types we define. Finally, our definition of access for repair interdependency specifically relates to the post-disaster recovery aspect of infrastructure resilience. As an example, debris, blocked roads, or failed bridges in the transportation network can prevent repair crews from accessing assets, e.g. power lines, to repair outages in other infrastructure systems, e.g. power. This interdependency type is an important addition for a focus on resilient infrastructure systems. Each interdependency type and the proposed method for probabilistically modeling it will be described in detail in the following sections.

Finally, we combine the interdependency types and analyze the full system to capture the interactions between interdependencies and assess infrastructure performance at an integrated system-of-systems level. To do this, 'system' nodes are created to represent levels of service over a region defined by geography or service area. For example, service levels may be based on the proportion of customers in a geographic area served by the infrastructures. The parents of the system node are the distribution components from each network in the area. The system nodes account for the relationships within systems as well as the combined effect of interdependencies across systems that impact the services received by the members of the community.

### Service provision interdependency

Service provision interdependency refers to the case where one component requires the service outputs of one or more components from another system to function. A simple example of this is a water pump requiring electricity from a power line to remain operational. To model a service provision interdependency, there is a direct dependence in the BN. The supplying component is a parent of the dependent component. A general assumption in building the BN is that the service is provided by the supply component nearest to the dependent component (Dueñas-Osorio et al., 2007). Additional information about the system topology and connections for a specific network is easily incorporated into the model through the dependency scheme described.

Figure 2 shows an example of the BN model for a service provision interdependency for a power system of components  $C_{1p}, \dots, C_{np}$  and water system of components  $C_{1w}, \dots, C_{nw}$ . The MLSs across both networks are numbered  $MLS_1, \dots, MLS_n$ . The subscripts p and w indicate nodes for the power and water systems, respectively. The dashed arrow represents the dependency between components. Using the example from above, component  $C_{np}$  represents the power line and  $C_{1w}$  the water pump relying on it to

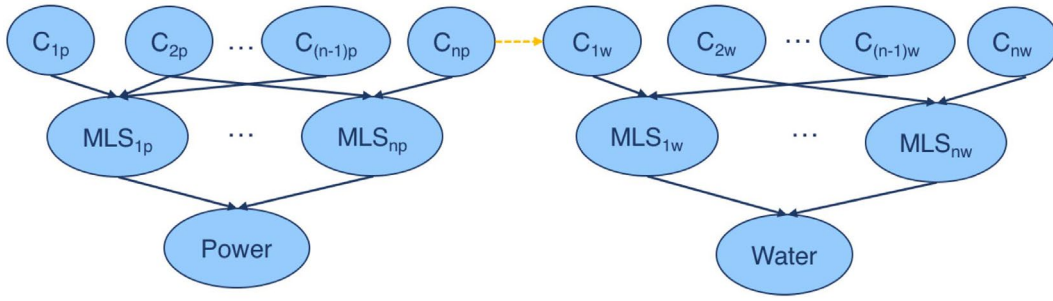

**Figure 2.** Example BN for service provision interdependency.

supply electricity. Therefore, the power line is a parent node of the water pump.

In general, if  $C_s$  represents the supply component and  $C_d$  represents the dependent component, the CPT for the dependent node incorporating the service provision interdependency is given in Equation (3) where  $p_f$  represents the original probability of failure of the dependent component.

$$P(C_d = \text{working}) = \begin{cases} 1 - p_f & \text{if } C_s \text{ working} \\ 0 & \text{if } C_s \text{ failed} \end{cases} \quad (3)$$

$$P(C_d = \text{failed}) = \begin{cases} p_f & \text{if } C_s \text{ working} \\ 1 & \text{if } C_s \text{ failed} \end{cases}$$

We also consider the case where the states of two components each depend on the functionality of the other, e.g. a water component depending on a power component for electricity and the power component depending on the same water component for cooling. It may appear that this introduces a cyclic dependency into the BN, which is an acyclic graphical framework. However, this dependency relationship is treated by defining the components by their joint probability distribution and choosing one of the components to be the parent of the other. Regardless of the choice of parent, the CPT is defined using the joint probabilities divided by the marginal probabilities of failure. For example, for the power and water components each depending on the other as in the example above, the CPT would be as shown in Table 1.

The joint probabilities are calculated by considering the possibility of each state of the components and then using total probability to calculate the remaining entries. In Table 1, the probability of  $C_{1w}$  failed and  $C_{np}$  working is zero because they both must be in the working state for either one to function. The same concept is applied to the probability of  $C_{1w}$  working and  $C_{np}$  failed, also resulting in zero. Total probability can then be used to calculate the other two entries in the CPT to be one. The same approach can be used for components with more than two states.

**Table 1.** CPT for service provision interdependency where the states of two components each depend on the other.

$C_{1w}$	$C_{np}$ Working	$C_{np}$ Failed
Working	$p(C_{1w} = \text{working}, C_{np} = \text{working})$	$p(C_{1w} = \text{working}, C_{np} = \text{failed})$
Failed	$p(C_{1w} = \text{failed}, C_{np} = \text{working})$	$p(C_{1w} = \text{failed}, C_{np} = \text{failed})$

### Geographic interdependency

Components in the same geographic area are related by a geographic interdependency. For example, if several components are located near to each other, they are likely to fail simultaneously if a hazard were to occur in that specific area. Infrastructure that is collocated, such as a gas line and water line routed along the same road, are more likely to fail together under a common hazard event. In these cases, information about the state of one component will affect the estimation of the state of the nearby component.

To model this interdependency, the given geographic area where the infrastructure is located is partitioned into regions. The regions can be determined based on collocated nodes or differing probabilities of hazard that exist over an area. The definition of partitions is flexible based on the available data and areas of interest, from local, to citywide, regional, national, or even global scales. The dependency between component nodes in a specific partition is modeled through a common hazard parent node that accounts for the probabilities of different hazard levels or intensities. Multiple hazard nodes for any set of components can be included to capture impacts of multiple hazards on the network.

In constructing the CPTs for the component nodes, the component failure probabilities become conditional probabilities of failure due to a hazard of a given magnitude. From a Bayesian inference point of view, knowledge about one component updates the hazard probability distribution, which updates the posterior distributions of the other dependent components. For example, BN incorporating a geographic interdependency is shown in Figure 3, for two

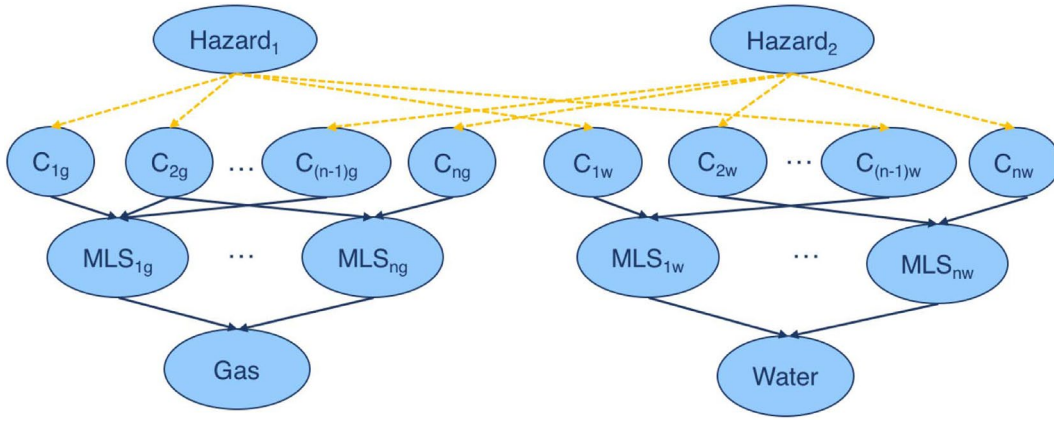

**Figure 3.** Example BN for geographic interdependency.

hazard regions, Hazard<sub>1</sub> and Hazard<sub>2</sub>, and where C<sub>1g</sub>, C<sub>2g</sub>, C<sub>1w</sub>, and C<sub>(n-1)w</sub> are in one hazard area and C<sub>(n-1)g</sub>, C<sub>ng</sub>, C<sub>2w</sub> and C<sub>nw</sub> are in another hazard area.

In general, the CPTs for a hazard node and dependent component node accounting for the geographic interdependency are constructed using Equations (4) and (5), respectively.  $p_i$ ,  $i = 1, \dots, k$ , represents the probability of a level  $i$  hazard.

$$P(\text{hazard level } i) = p_i \quad (4)$$

$$\begin{aligned} P(C = \text{working}) \\ = 1 - p(\text{failure}|\text{hazard level } i) \text{ for } i = 1, \dots, k \end{aligned} \quad (5)$$

$$P(C = \text{failed}) = p(\text{failure}|\text{hazard level } i) \text{ for } i = 1, \dots, k$$

### Access for repair interdependency

To improve system resilience, if certain infrastructure components are damaged due to a disruptive event, other components must be functional to provide both cyber and physical access to the failed components for repair. This is defined as an access for repair interdependency. For example, if a component is failed, a communication tower may be necessary for reporting the failure, or roads and bridges must be functional for repair crews to access the failed component. This type of interdependency specifically addresses the post-disaster restoration and recovery aspect of resilience.

To model this interdependency, access nodes are created as parent nodes of the components that depend on them for access. In the case of cyber access, these nodes account for the ability to connect with the component and robustness of the communication channels to potential disruptions; for physical access, the nodes account for level of remoteness and degree of redundancy in paths to reach the component. For example, if a component is far from the service dispatch station with a single route for

access, the probability of repair may be lower compared to a component closer to the station due to increased probability that the road to access the component is blocked. In that case, the existence of alternate routes for access would increase the probability of repair.

When modeling the access for repair interdependency, the evolution of an infrastructure system over time must be taken into account. Specifically, if a component is working, its state is independent of the state of its connected communication or transportation networks; it is only when the component is failed that a dependency with access networks exists and connection to these networks is required for repair. To model the dynamic nature of failure and recovery processes, a node representing the previous state in time of the dependent component is created. This allows the determination of the need to account for the state of an access node in the analysis over time. For example, BN with an access road node is shown in Figure 4.  $C_{1p}$ <sub>previous</sub> indicates the state of the component in the previous time step, and  $p_f$  represents the prior probability of failure. In general, if  $C_a$  represents the access node and  $p_{\text{repair}}$  represents the probability that the component is repaired, the CPT for the dependent component  $C_d$  incorporating the access for repair interdependency is given in Equation (6).

$$\begin{aligned} P(C_d = \text{working}) \\ = \begin{cases} 1 - p_f & \text{if } C_{d\text{previous}} \text{ working} \\ p_{\text{repair}} & \text{if } C_{d\text{previous}} \text{ failed and } C_a \text{ working} \\ 0 & \text{if } C_{d\text{previous}} \text{ failed and } C_a \text{ failed} \end{cases} \quad (6) \end{aligned}$$

$$\begin{aligned} P(C_d = \text{failed}) \\ = \begin{cases} p_f & \text{if } C_{d\text{previous}} \text{ working} \\ 1 - p_{\text{repair}} & \text{if } C_{d\text{previous}} \text{ failed and } C_a \text{ working} \\ 1 & \text{if } C_{d\text{previous}} \text{ failed and } C_a \text{ failed} \end{cases} \end{aligned}$$

$p_{\text{repair}}$  can be defined in a number of ways, including based on the level of damage to the component or a metric that accounts for the importance of the node in the network. Incorporating dynamic equations for probability of repair is possible to enable calculations of a time to repair for each node by evaluating the BN over multiple time slices. For generalized systems,  $p_{\text{repair}}$  can be calculated based on a function of the damage to the component. One example is in Rackwitz and Joanni (2009), where the probability of repair is represented as the probability that a monotonically increasing damage indicator exceeds a given

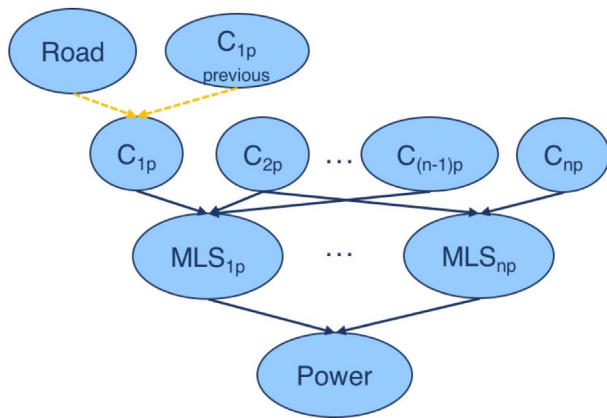

Figure 4. Example BN for access for repair interdependency.

threshold level such that higher damage components have higher likelihoods of repair.

## Application

The generalized modeling methodologies presented in the previous section are now applied to a real network of interdependent water, power, and gas systems in Shelby County, Tennessee, to illustrate their use. The network overlaid onto a map of the county is shown in Figure 5. Each network is shown, with different symbols indicating differing functionalities of individual nodes in the network. The power network is made up of 60 components – 8 gate nodes, 37 substations, and 15 transshipment nodes – and 74 links. The water network is comprised of 49 nodes – 15 gate nodes and 34 distribution nodes – and 78 links. The gas network is made up of 16 nodes – 3 gate nodes, 6 transshipment nodes, and 7 distribution nodes – and 17 links (González, Dueñas-Osorio, Sánchez-Silva, & Medaglia, 2015). Gate nodes refer to source nodes such as high voltage power substations, water storage tanks, or large pumping stations. Transshipment nodes are points where several lines meet and redistribute resources. In the power network, substations are electrical substations. In the water and gas networks, distribution nodes are pipe junctions, terminal points, and gas regulator stations (Hernandez-Fajardo & Dueñas-Osorio, 2013). Links refer

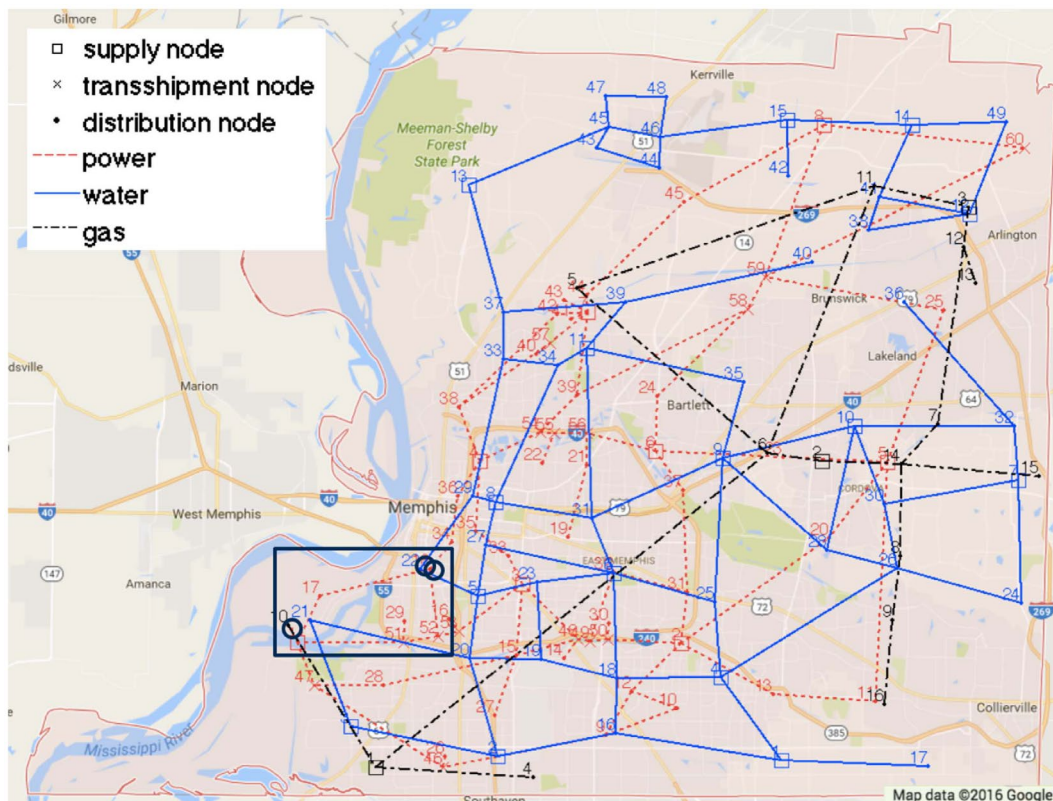

Figure 5. Interdependent power, water, and gas networks in Shelby County, TN; Memphis nodes framed. Source: Google Trademark visible in the figure: <https://www.google.com/permissions/geoguidelines.html>.

to the connections between these different assets including power lines and water and gas pipes.

Failure probabilities for each component are input into the BN. In general, these can be found based on fragility curves; mechanical properties of the component,

e.g. material and degradation due to age; and based on historical data. Here, the component failure probabilities are calculated based on fragility curves for earthquakes of moment magnitudes six, seven, eight, and nine from González et al., 2015;. The failure probabilities for each

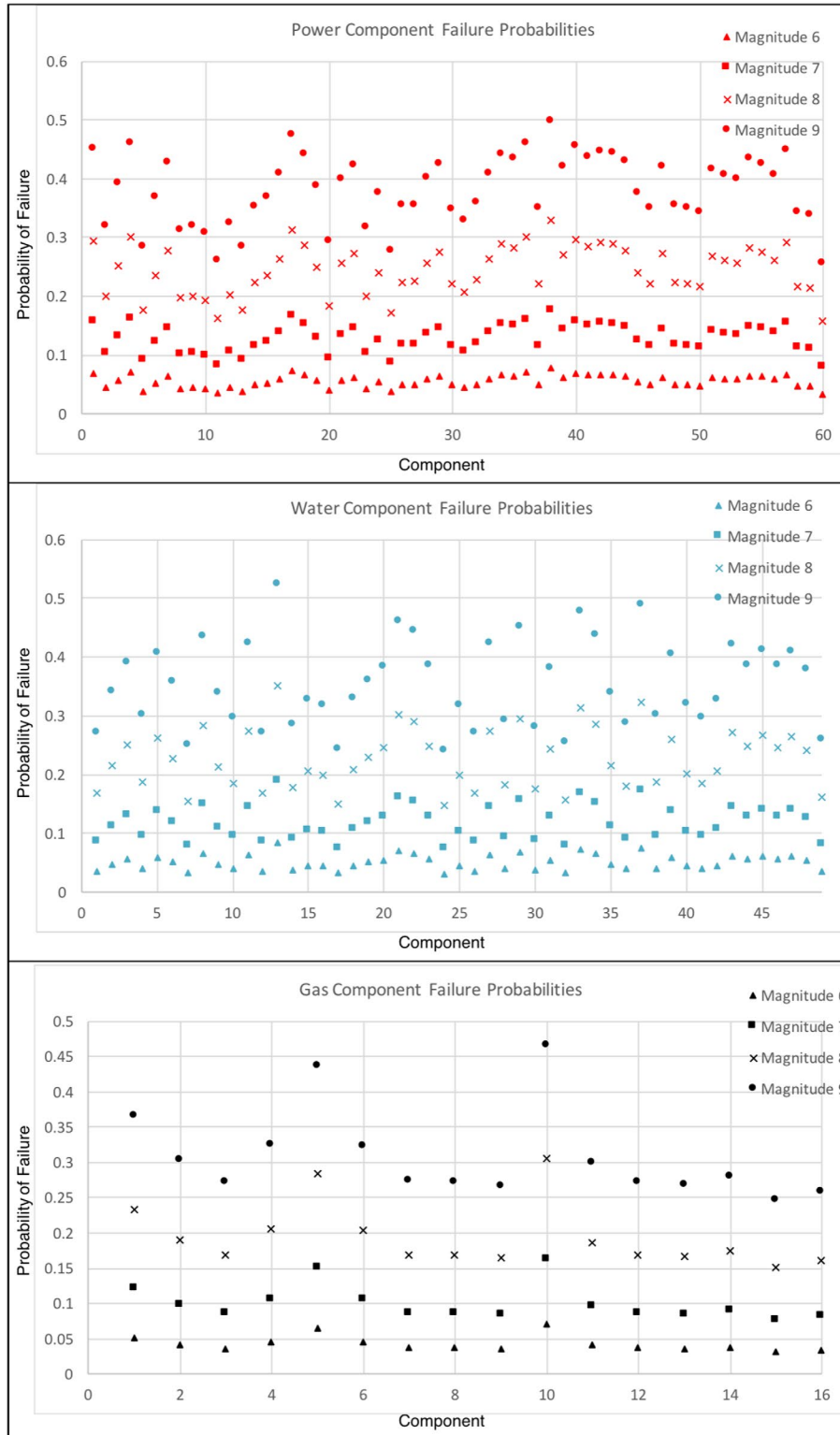
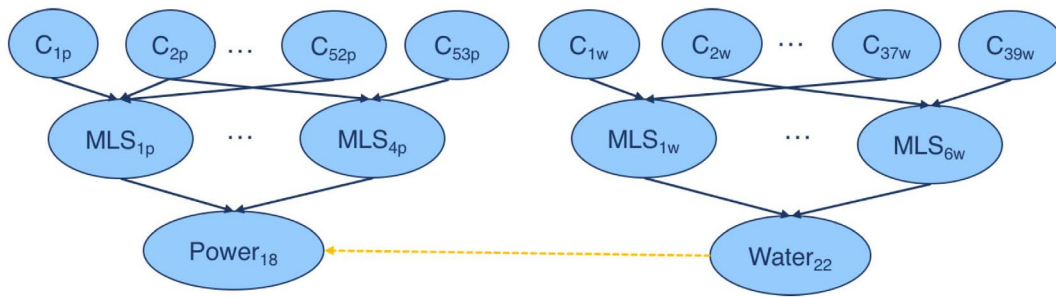

Figure 6. Failure probabilities for power, water, and gas nodes in Shelby County, TN, under varying earthquake moment magnitudes.





**Figure 7.** BN for Memphis service provision interdependency.

component in the power, water, and gas networks are shown in Figure 6.

In Figure 5, the three nodes for each network that are closest to the city of Memphis are framed and circled and used as examples for inference. These are the  $Power_{18}$ ,  $Water_{22}$ , and  $Gas_{10}$ . The full network and larger interdependent systems can be assessed using the methodology; these nodes are chosen for clarity in presentation of the results. These three nodes are used for inference because of their proximity to the largest metropolitan area in Shelby County. The application describes how the interdependencies are modeled on a small scale, and the methodology can be expanded to the entire network. In the example, the power component closest to Memphis is a substation. There are four MLSs that connect this power component to a gate station. The water node closest to Memphis is a distribution node. There are six MLSs that connect this water node to a gate node. One MLS connects the gas distribution node closest to Memphis to a gate node. In general, for a network of gate, transshipment, and distribution nodes, MLSs are defined as the minimum set of components that must be functioning to provide the resource, e.g. power, water, or gas, from a gate to a transshipment or distribution node.

To perform the inference, we run the BN using Hugin Expert, a BN modeling software. The identification of MLSs is the largest computational burden for the overall network. We perform the MLS identification on the full Shelby County network made up of 60 power nodes, 49 water nodes, and 18 gas nodes. This computation takes approximately 19 s on an 4 GB RAM computer using MATLAB R2015a. For the three power, water, and gas nodes closest to Memphis, identifying the MLSs and analyzing the BN is done instantaneously. For inference, probabilistic outcomes under varying scenarios are obtained by inputting evidence, e.g. changing the likelihoods of component survival or failure or hazard occurrence, then observing the results. Example inferences using the built BN model are presented in the following sections.

**Table 2.** CPT for power node for service provision interdependency inference.

	Water node survives (%)	Water node fails (%)
Power Node Survives	99.6	0
Power Node Fails	.4	100

### Service provision interdependency

In this example, the water distribution station supplies cooling for the power substation. If the water node fails, the power node will as well; therefore, there is a direct dependence between these two components, as shown in Figure 7. The MLS nodes for both power and water are shown in the BN as well.

The prior probability of failure of the power node is calculated based on fragility curves given four earthquake moment magnitudes – six, seven, eight, and nine. Other specific component-level information is easily incorporated through the component node CPTs. This allows component-level models including physical performance and control system variables to be included in defining the component probabilities of failure. Table 2 shows the effect of the service provision interdependency on the power node. In this simple example, if the water node fails, it is certain that the power node will fail as well.

### Geographic interdependency

To model the geographic interdependency, Shelby County is separated into nine partitions. The components comprising the MLSs in the system are located in five different partitions, labeled Hazards 1, 4, 6, 7, and 9. The power and water nodes closest to Memphis are in Hazard partition 6; the gas node is within Hazard partition 1. Earthquake hazard is considered in this example, with each hazard node accounting for the probability of no earthquake and of an earthquake of moment magnitude six, seven, eight, or nine. The CPTs for the components reflect the conditional probabilities of failure in the event of no hazard, and under

earthquakes of the aforementioned magnitudes. The BN for the geographic interdependency is shown in Figure 8.

Inference accounting for this interdependency results in the probability of survival of components given varying levels of earthquake magnitude – whether based on observed information after an earthquake has occurred, or from running what-if scenarios for potential earthquake events – as shown in Table 3. The probability of survival decreases as the earthquake magnitude increases. 100.0% survival under the no hazard scenario is due to rounding to the nearest 10th of a percent.

**Access for repair interdependency**

For the Shelby County system, the transportation network is used to demonstrate the access for repair interdependency. Taking the two highest functional classifications of roads, the closest freeway, interstate, or principal arterial is used as the access node for a component. A map of the road network used as overlaid onto the system of interest is shown in Figure 9.

For the example case, a segment of Interstate 1 is closest to the power and water nodes and a segment of Interstate 55 is closest to the gas node. If those interstate sections are failed, it is assumed that there will be no access to the components for repair. Nodes representing smaller roads and alternate routes can be added to the BN model. In our example, to show the effect of access, it is assumed that the probability of repair given access is 1. This assumes that every node that fails is prioritized for repair. Figure 10 illustrates the access for repair interdependency. To represent the dependence of the component states on access nodes in the case of component failure and independence otherwise, nodes providing the previous state

of the infrastructure component, i.e. working or failed, are shown.

Table 4 shows scenario combinations of Interstate 1 and Interstate 55 surviving and failing and the effect of those combinations on the states of the power, water, and gas nodes closest to Memphis. If Interstate 1 fails, the power and water nodes’ probabilities of survival decrease by about 1.3 and .3%, respectively. If interstate 55 fails, the gas node’s probability of survival decreases by approximately 1.2%. These changes are small due to the low failure probabilities of the power, water, and gas components themselves. Since the road is not needed if the nodes survive, their probabilities of survival remain relatively high. In addition, while effects a priori are small, in cases where component failure is known, it becomes necessary to repair the access networks to enable repair of the dependent systems. In these cases, the effect is larger and it is important to have included these relationships in the network model.

**BN model**

Figure 11 shows the BN model of the three power, gas, and water nodes and all of their interdependencies. Moving left to right through the BN, the leftmost nodes show the hazard (hazard by partition number) and access nodes (I1 and I55) that account for geographic and access for repair interdependencies. The next layer shows the three nodes being modeled closest to Memphis. The shaded nodes represent the dynamic component states in the previous time step. The link between the power and water nodes shows the service provision interdependency. The MLSs are on the next level. As previously described, there are four MLSs for the power node, one for the gas node,

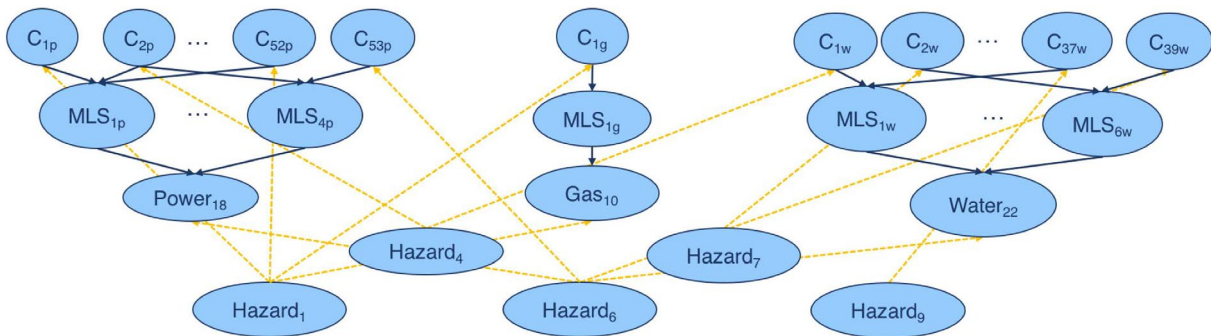

**Figure 8.** BN for Memphis geographic interdependency.

**Table 3.** CPT for power node for geographic interdependency inference.

	No Hazard (%)	Magnitude 6 (%)	Magnitude 7 (%)	Magnitude 8 (%)	Magnitude 9 (%)
Power Node Survives	100.0	97.6	83.3	45.7	13.6
Water Node Survives	100.0	98.5	92.0	73.8	49.5
Gas Node Survives	100.0	83.1	63.9	40.1	20.7

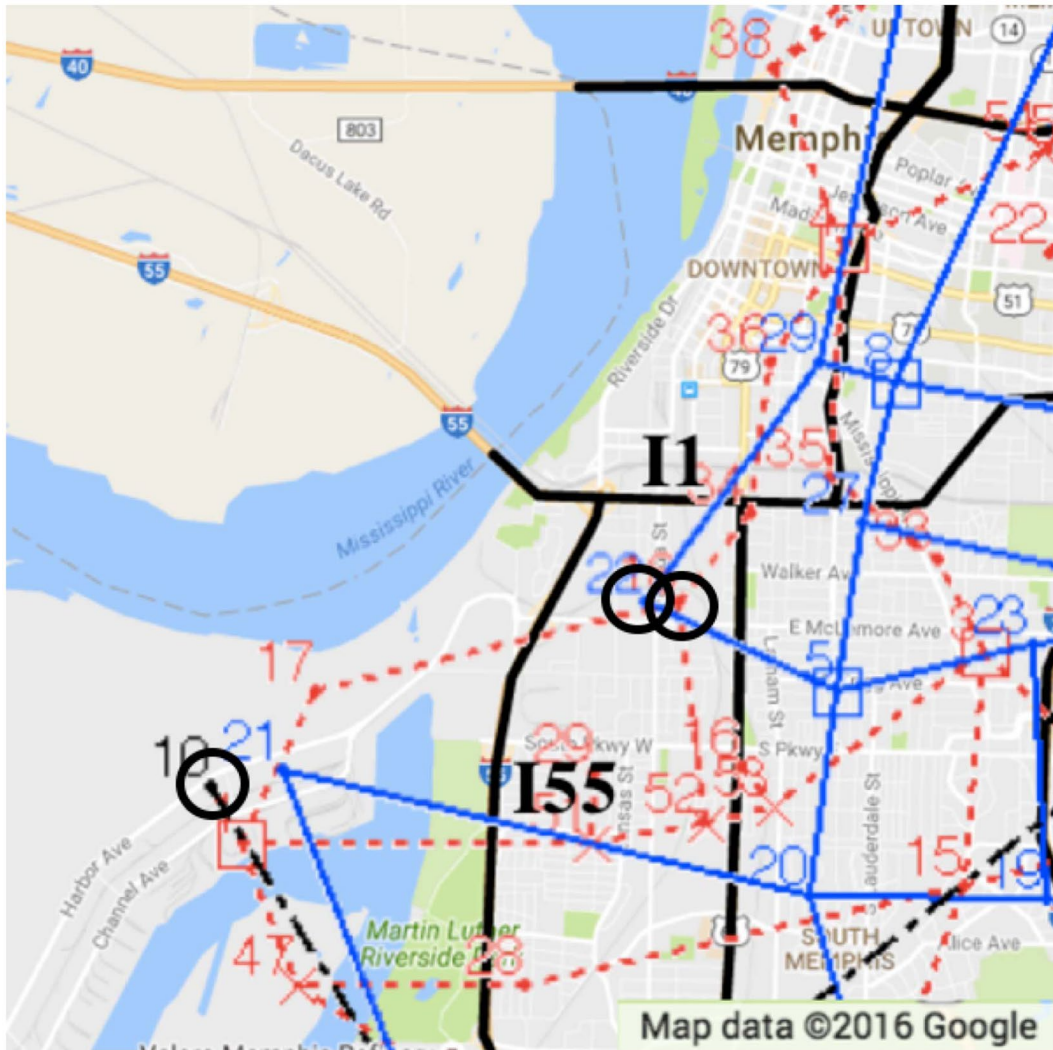

Figure 9. Freeways, interstates, and principal arterials surrounding Memphis.

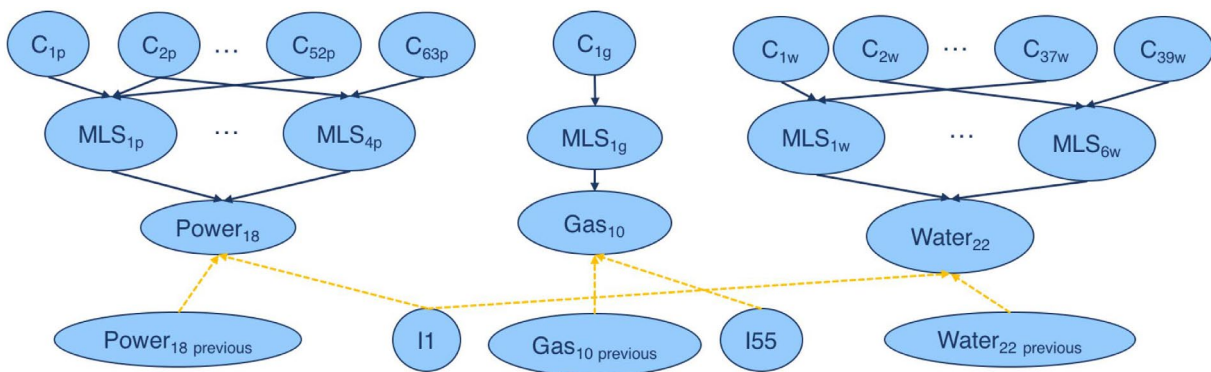

Figure 10. BN for Memphis access for repair interdependency.

Table 4. CPT for power, water, and gas nodes for access for repair interdependency inference.

	I1 Survives & I55 Survives (%)	I1 Fails & I55 Survives (%)	I1 Survives & I55 Fails (%)	I1 Fails & I55 Fails (%)
Power Node Survives	96.5	94.2	96.5	94.2
Water Node Survives	96.8	96.5	96.8	96.5
Gas Node Survives	93.2	93.2	92.0	92.0

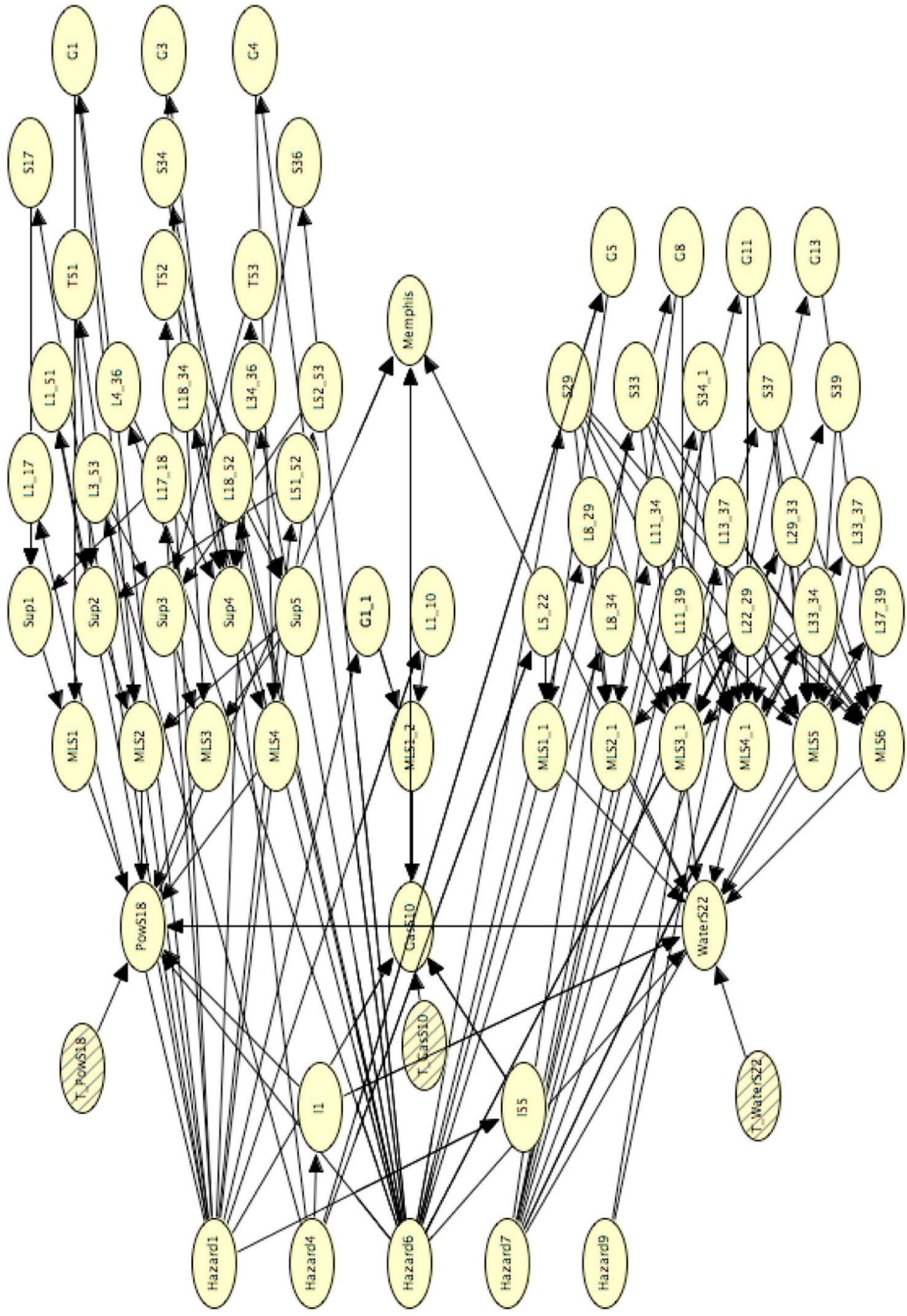

Figure 11. Bayesian network incorporating all interdependencies for the Memphis power, gas, and water nodes.

**Table 5.** Inference for combined ‘Memphis’ node.

	No Evidence (%)	Hazard <sub>1</sub> Occurs (%)	Hazard <sub>4</sub> Occurs (%)	Hazard <sub>6</sub> Occurs (%)	Hazard <sub>18</sub> Occurs (%)	Hazard <sub>22</sub> Occurs (%)
Memphis Survives	86.5	49.9	86.0	64.5	86.5	86.5
Memphis Fails	13.5	50.1	14.0	35.5	13.5	13.5

and six for the water node. For the power node, a layer of five super-components (Sup1, ..., Sup5) follows. The remaining nodes in the BN represent the individual components (labeled L for links, T for transshipment nodes, S for substations/distribution nodes, and G for gate nodes) that comprise the MLSs and super-components for those nodes.

With the full model, inference over the network enables assessment of system performance incorporating all interdependencies. By performing analyses for specific components and observing the resulting performance of the interdependent systems, it enables quantification of cascading effects beyond initial disruptions to a single network. Comparing system outcomes based on varying component behaviors facilitates evaluation of the network and identification of the critical nodes. During a disaster event, rapid updating of the states of all components using the built BN model facilitates recovery decisions. For example, a decision-maker can determine the impact of the repair of each of the components that failed during the disaster event. Those components with the largest effects on system performance measured by, e.g. ability to provide service to a critical facility such as a hospital or based on an overall system metric would be prioritized for repair over less impactful components. For pre-, during, and post-hazard planning and response, running analyzes over multiple recovery scenarios supports identification of critical components for repair, retrofit, or replacement to minimize the risk of cascading failures and increase resilience. For pre-hazard planning in particular, critical components can be identified and either retrofitted or replaced to prevent or minimize damage from future disruptions.

In Figure 11, a node (labeled as ‘Memphis’) representing the combined outputs from the three nodes closest to Memphis (Power<sub>18</sub>, Water<sub>22</sub>, and Gas<sub>10</sub>) is used to represent the integrated effects of all interdependencies. This measure of infrastructure performance at the system-of-systems level is defined similarly to a MLS, where the city is said to have ‘survived’ if all distribution stations (power, water, and gas) closest to Memphis have service, and is ‘failed’ otherwise. Inference is performed by inputting evidence of a magnitude seven earthquake occurring throughout each partition. Results are shown in Table 5. The hazard subscripts indicate hazard locations by partition.

In Table 5, occurrences of an earthquake in hazard zones one and six have large impacts on the Memphis service as they also affect the access nodes. Because we define survival of Memphis as requiring all three distribution nodes to survive, the probability of failure is relatively high. For comparison, the individual prior survival probabilities are 94% for power<sub>18</sub>, 96% for water<sub>22</sub>, and 92% for gas<sub>10</sub>.

In the BN model in Figure 11, the geographic interdependencies are accounted for using the hazard nodes. The service provision interdependencies are modeled using the direct dependency relationships added in the BN. The access nodes (I1 and I55) are children of the hazard nodes, parents of the component nodes, and represent the access for repair interdependency. Many studies on infrastructure systems have focused on the Shelby County, Tennessee, and networks. In relation to these, the failure probabilities used in this study are from HAZUS models calculated previously (Elnashai, Cleveland, Jefferson, & Harrald, 2009 and Kim, Spencer, Song, Elnashai, & Stokes, 2007). The proposed interdependency models include an analogy to geographical immediacy (Dueñas-Osorio et al., 2007). Additionally, an adjacency matrix defining the network connectivity (Dueñas-Osorio et al., 2007) is used for generating the MLSs in our BN model. Overall, the proposed method uses the BN to probabilistically model the interdependent infrastructure systems and provides several efficiency improvements to prior approaches with the increased inference capabilities of the BN framework.

## Conclusion

In order to create more resilient infrastructure, it is necessary to understand the individual systems as well as the relationships between them comprehensively. By clearly defining three interdependency types between infrastructures – service provision, geographic, and access for repair – one can gain a deeper understanding of the systems overall and prioritize repair and reinforcement of components taking into account the effects of their performance both within individual systems and across multiple infrastructure networks. BNs are effective in this application because of the ability to capture the complexities of the network, including its interdependencies; to model uncertainty, including in hazards and in information

about components and system connections; and to update assessments across the network.

The full BN model that is created using the method presented accounts for all dependencies and interdependencies between infrastructures. First, component nodes are modeled. Each component has parent nodes, which are the MLSs for that component, indicating performance of the component based on flow through the rest of the system on which it depends. These MLSs are made up of the components and super-components that comprise the set. Links are then added for each of the service provision interdependencies. The BN includes hazard nodes as parents of each component by location. All components in a geographic partition are connected to a hazard node, with component nodes defined according to their states in that partition. Access nodes are created that account for the level of remoteness for all components and the ability to repair these components in the case of failure. System nodes that represent the states of the infrastructures indicate flow through the systems and the level of service provided by each network overall.

Analyses using the multi-scale BN framework show the effects of individual component performance on network performance taking into account the complex interdependencies that exist between infrastructure systems. The BN model enables these assessments to be performed probabilistically. Understanding the effects of the interdependencies on the fragility of the systems supports decision-making in their design, management, and restoration to create more resilient critical infrastructure.

## Acknowledgements

This work was supported by the National Science Foundation under Grant DGE-1148903. Support from National Science Foundation Grant CNS-1541074 is also acknowledged.

## Disclosure statement

No potential conflict of interest was reported by the authors.

## Funding

This work was supported by the National Science Foundation [grant number DGE-1148903] and [grant number CNS-1541074].

## Notes on contributors

*Chloe Johansen* is a doctoral candidate at Georgia Institute of Technology. Her research focus is probabilistically modeling interdependent infrastructure systems to increase system resilience.

*Iris Tien* is an assistant professor in the School of Civil and Environmental Engineering at the Georgia Institute of Technology. Her research is in risk and reliability of civil infrastructure systems, with contributions in the areas of complex systems modeling, structural reliability, and data analytics for infrastructure resilience.

## ORCID

*Chloe Johansen*  <http://orcid.org/0000-0002-5558-0802>

## References

- American Society of Civil Engineers. (2013). *2013 Report card for America's infrastructure*. <http://www.infrastructurereportcard.com>
- Bensi, M., Kiureghian, A., & Straub, D. (2013). Efficient Bayesian network modeling of systems. *Reliability Engineering & System Safety*, *112*, 200–213.
- Bobbio, A., Portinale, L., Minichino, M., & Ciancamerla, E. (2001). Improving the analysis of dependable systems by mapping fault trees into Bayesian networks. *Reliability Engineering and System Safety*, *71*, 249–260.
- Bruneau, M., & Reinhorn, A. (2004). Measuring improvements in the disaster resilience of communities. *EERI Spectra Journal*, *20*, 739–755.
- Der Kiureghian, A., & Song, J. (2008). Multi-scale reliability analysis and updating of complex systems by use of linear programming. *Reliability Engineering and System Safety*, *93*, 288–297.
- Dudenhofer, D. D., Permann, M. R., & Manic, M. (2006). *CIMS: a framework for infrastructure interdependency modeling and analysis*. Proceeding of the 2006 Winter Simulation Conference.
- Dueñas-Osorio, L., Craig, J. I., & Goodno, B. (2007). Seismic response of critical interdependent networks. *Earthquake Engineering and Structural Dynamics*, *36*, 285–306. doi:10.1002/eqe.626
- Elnashai, A. S., Cleveland, L. J., Jefferson, T., & Harrald, H. (2009). Impact of New Madrid Seismic Zone earthquakes on the Central USA. *MAE Center Report. CD Release*, 09–03.
- Franchin, P., & Cavalieri, F. (2015). Probabilistic assessment of civil infrastructure resilience to earthquakes. *Computer-Aided Civil and Infrastructure Engineering*, *30*, 583–600.
- González, A. D., Dueñas-Osorio, L., Sánchez-Silva, M., & Medaglia, A. L. (2015). The interdependent network design problem for optimal infrastructure system restoration. *Computer-Aided Civil and Infrastructure Engineering*, *31*, 334–350.
- Guidotti, R., Chmielewski, H., Unnikrishnan, V., Gardoni, P., McAllister, T. P., & van de Lindt, J. (2016). Modeling the resilience of critical infrastructure: The role of network dependencies. *Sustainable and Resilient Infrastructure*, *1*, 153–168.
- Haimes, Y. Y. (2008). Models for risk management of systems of systems. *International Journal of System of Systems Engineering*, *1*, 222–236.
- Hernandez-Fajardo, I., & Dueñas-Osorio, L. (2013). Probabilistic study of cascading failures in complex

- interdependent lifeline systems. *Reliability Engineering and System Safety*, 111, 260–272. doi:10.1016/j.res.2012.10.012
- Hosseini, S., & Barker, K. (2016). Modeling infrastructure resilience using Bayesian networks: A case study of inland waterway ports. *Computers & Industrial Engineering*, 93, 252–266.
- Jiang, X., Bai, R., Atkin, J., & Kendall, G. (2016). A scheme for determining vehicle routes based on Arc-based service network design. *Information Systems and Operational Research*, 55, 16–37.
- Johansen, C., Horney, J., & Tien, I. (2016). Metrics for evaluating and improving community resilience, 23(2). *ASCE Journal of Infrastructure Systems*. doi:10.1061/(ASCE)IS.1943-555X.0000329
- Kang, W.-H., Song, J., & Gardoni, P. (2008). Matrix-based system reliability method and applications to bridge networks. *Reliability Engineering and System Safety*, 93, 1584–1593.
- Kim, M. C. (2011). Reliability block diagram with general gates and its application to system reliability analysis. *Annals of Nuclear Energy*, 38, 2456–2461.
- Kim, Y., Spencer, B. F., Song, H., Elnashai, A. S., & Stokes, T. (2007). Seismic performance assessment of interdependent lifeline systems. *MAE Center CD Release*, 07–16.
- Korkali, M., Veneman, J. G., Tivnan, B. F., & Hines, P. D. H. (2014). Reducing cascading failure risk by increasing infrastructure network interdependency. Retrieved from <https://arxiv.org/abs/1410.6836>
- Kurtz, N., Song, J., & Gardoni, P. (2015). Seismic reliability analysis of deteriorating representative US West Coast bridge transportation networks. *ASCE Journal of Structural Engineering*, 142, 335–369.
- Lee, Y.-J., Song, J., Gardoni, P., & Lim, H.-W. (2011). Post-hazard flow capacity of bridge transportation network considering structural deterioration of bridges. *Structure and Infrastructure Engineering*, 7, 509–521.
- Leontief, W. W. (1951). Input-output economics. *Scientific American*, 185, 15–21.
- Mahadevan, S., Zhang, R., & Smith, N. (2001). Bayesian networks for system reliability reassessment. *Structural Safety*, 23, 231–251.
- Ouyang, M. (2014). Review on modeling and simulation of interdependent critical infrastructure systems. *Reliability Engineering and System Safety*, 121, 43–60. doi:10.1016/j.res.2014.06.040
- Rackwitz, R., & Joanni, A. (2009). Risk acceptance and maintenance optimization of aging civil engineering infrastructures. *Structural Safety*, 31, 251–259.
- Rinaldi, S. M., Peerenboom, J. P., & Kelly, T. (2001). Identifying, understanding, and analyzing critical infrastructure interdependencies. *IEEE Control Systems Magazine*, 11–25.
- Rose, A., & Miernyk, W. (1989). Input-output analysis: The first fifty years. *Economic Systems Research*, 1, 229–272.
- Tien, I., & Der Kiureghian, A. (2013). Compression algorithm for Bayesian network modeling of binary systems. In G. Deodatis, B. Ellingwood, and D. Frangopol, Eds., *Safety, Reliability, Risk and Life-Cycle Performance of Structures and Infrastructures*, New York: CRC Press, 3075–3081.
- Tien, I. (2014). *Bayesian network methods for modeling and reliability assessment of infrastructure systems* (Doctoral thesis). Berkeley: University of California.
- Tien, I., & Der Kiureghian, A. (2015). *Compression and inference algorithms for Bayesian network modeling of infrastructure systems*. Proceedings of the 12th International Conference on Applications of Statistics and Probability in Civil Engineering, T. Haukaas, ed.
- Tien, I., & Der Kiureghian, A. (2016). Algorithms for Bayesian network modeling and reliability assessment of infrastructure systems. *Reliability Engineering and System Safety*, 156, 134–147.
- White House. (2013). *Presidential policy directive/PPD 21 – Critical infrastructure security and resilience*. Washington, DC.
- Zhang, P., & Peeta, S. (2011). A generalized modeling framework to analyze interdependencies among infrastructure systems. *Transportation Research Part B: Methodological*, 45, 553–579.